



# FR-D700 Series

Low cost micro VFD with Mitsubishi Electric quality.

- **Simple to use:** The FR-D700 is perfect for a wide range of applications
- **Simple to set-up:** The integrated digital setting dial with display makes configuration fast and easy
- **Simple operation:** Control remotely or with the built-in digital control
- **Simple to choose:** Low cost and with Mitsubishi Electric quality ensuring long operation life
- **Capacity:** From 1/8 to 20 HP
- **Safety stop function:** Meets EN954-1 Category 3 and IEC60204-1 Stop Category 0
- Integrated brake chopper circuit
- **MODBUS RTU:** Included as standard via the RJ45 port
- **150% torque at 1Hz and 200% torque at 3Hz** using General-purpose Magnetic Flux Vector Control
- **Optimum Excitation Control:** For increased energy savings when motor is not loaded
- **Frequency search function:** Catch a spinning load
- **Dancer control:** Allows position signal to control roll tension
- **Password function:** For parameter setting protection
- **Internal diagnostics function:** For monitoring status of critical components
- RoHS compliant
- 10 year maintenance free design



## FR- 1 - 2 -NA

### 1 Max Load Capacity

Symbol	Voltage Class
D710W	1-phase 110V class
D720S	1-phase 240V class
D720	3-phase 240V class
D740	3-phase 480V class

### 2 Capacity

Symbol
Inverter capacity amperage / 10 (008 = 0.8A output)

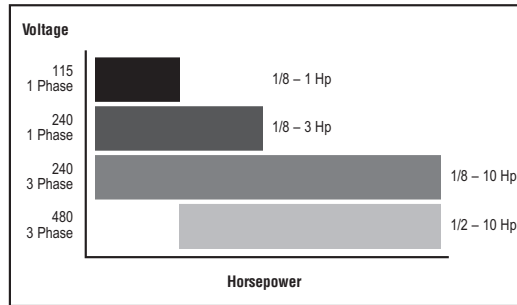

## FR-D700 Series

Rating (CT & VT)		IP20 Open Chassis	Dimensions in inches (mm)			Weight lbs (kg)	Stocked Item
HP	Rated Amps	Model Number	Height	Width	Depth		
<b>1-Phase 100~120VAC Input / 3-Phase 200~240VAC Output</b>							
1/8	0.8	FR-D710W-008-NA	5.0 (128)	2.7 (68)	3.2 (80.5)	1.1 (0.5)	S
1/4	1.4	FR-D710W-014-NA	5.0 (128)	2.7 (68)	4.4 (110.5)	1.3 (0.6)	S
1/2	2.5	FR-D710W-025-NA	5.0 (128)	2.7 (68)	5.6 (142.5)	2.0 (0.9)	S
1	4.2	FR-D710W-042-NA	5.0 (128)	4.3 (108)	5.9 (149.5)	3.1 (1.4)	S
<b>1-Phase 200~240VAC Input / 3-Phase 200~240VAC Output</b>							
1/8	0.8	FR-D720S-008-NA	5.0 (128)	2.7 (68)	3.2 (80.5)	1.1 (0.5)	S
1/4	1.4	FR-D720S-014-NA	5.0 (128)	2.7 (68)	3.2 (80.5)	1.3 (0.6)	S
1/2	2.5	FR-D720S-025-NA	5.0 (128)	2.7 (68)	5.6 (142.5)	2.0 (0.9)	S
1	4.2	FR-D720S-042-NA	5.0 (128)	2.7 (68)	6.5 (162.5)	2.5 (1.1)	S
2	7	FR-D720S-070-NA	5.0 (128)	4.3 (108)	6.2 (155.5)	3.3 (1.5)	S
3	10	FR-D720S-100-NA	5.9 (150)	5.5 (140)	5.7 (145)	4.4 (2.0)	S
<b>3-Phase 200~240VAC Input &amp; Output</b>							
1/8	0.8	FR-D720-008-NA	5.0 (128)	2.7 (68)	3.2 (80.5)	1.1 (0.5)	S
1/4	1.4	FR-D720-014-NA	5.0 (128)	2.7 (68)	3.2 (80.5)	1.1 (0.5)	S
1/2	2.5	FR-D720-025-NA	5.0 (128)	2.7 (68)	4.5 (112.5)	1.8 (0.8)	S
1	4.2	FR-D720-042-NA	5.0 (128)	2.7 (68)	5.3 (132.5)	2.2 (1.0)	S
2	7	FR-D720-070-NA	5.0 (128)	4.3 (108)	5.4 (135.5)	3.1 (1.4)	S
3	10	FR-D720-100-NA	5.0 (128)	4.3 (108)	5.4 (135.5)	3.1 (1.4)	S
5	16.5	FR-D720-165-NA	5.0 (128)	6.7 (170)	5.6 (142.5)	4.0 (1.8)	S
7 1/2	23.8	FR-D720-238-NA	5.9 (150)	8.7 (220)	6.1 (155)	8.0 (3.6)	S
10	31.8	FR-D720-318-NA	5.9 (150)	8.7 (220)	6.1 (155)	8.0 (3.6)	S
<b>3-Phase 380~480VAC Input &amp; Output</b>							
1/2	1.2	FR-D740-012-NA	5.0 (128)	4.3 (108)	5.1 (129.5)	2.9 (1.3)	S
1	2.2	FR-D740-022-NA	5.0 (128)	4.3 (108)	5.1 (129.5)	2.9 (1.3)	S
2	3.6	FR-D740-036-NA	5.0 (128)	4.3 (108)	5.4 (135.5)	3.1 (1.4)	S
3	5	FR-D740-050-NA	5.0 (128)	4.3 (108)	6.2 (155.5)	3.3 (1.5)	S
5	8	FR-D740-080-NA	5.0 (128)	4.3 (108)	6.6 (165.5)	3.3 (1.5)	S
7 1/2	12	FR-D740-120-NA	5.9 (150)	8.7 (220)	6.1 (155)	7.3 (3.3)	S
10	16	FR-D740-160-NA	5.9 (150)	8.7 (220)	6.1 (155)	7.3 (3.3)	S

## FR-D700 General Specifications

Control Specifications	Control Method		Soft-PWM control/high carrier frequency PWM control (V/F control, General-purpose magnetic flux vector control, Optimum excitation control can be selected)	
	Output Frequency Range		0.2 to 400Hz	
	Frequency Setting Resolution	Analog Input	0.06Hz/60Hz (terminal2, 4: 0 to 10V/10bit) 0.12Hz/60Hz (terminal2, 4: 0 to 5V/9bit) 0.06Hz/60Hz (terminal4: 0 to 20mA/10bit)	
		Digital Input	0.01Hz	
	Frequency Accuracy	Analog Input	Within ±1% of the max. output frequency (25°C ±10°C)	
		Digital Input	Within 0.01% of the set output frequency	
	Voltage/Frequency Characteristics		Base frequency can be set from 0 to 400Hz. Constant torque/variable torque pattern can be selected	
	Starting Torque		150% or more (at 1Hz) when General-purpose magnetic flux vector control and slip compensation is set	
	Torque Boost		Manual torque boost	
	Accel. /Decel. Time Setting		0.01 to 3600s (acceleration and deceleration can be set individually), linear or S-pattern acceleration/deceleration mode can be selected.	
Braking Torque	Regeneration (*1)	FR-D720-008 and 014, FR-D720S-008 and 014, FR-D710W-008 and 014 ... 150%, FR-D720-025 and 042, FR-D740-012 and 022, FR-D720S-025 and 042, FR-D710W-025 and 042 ... 100%, FR-D720-070, FR-D740-036, FR-D720S-070 ... 50%, FR-D720-100 or more, FR-D740-050 or more, FR-D720S-100 ... 20%		
	DC Injection Brake	Operation frequency (0 to 120Hz), operation time (0 to 10s), operation voltage (0 to 30%) variable		
Stall Prevention Operation Level		Operation current level can be set (0 to 200% adjustable), whether to use the function or not can be selected		
Operation Specifications	Frequency Setting Signal	Analog Input	Two points Terminal 2: 0 to 10V, 0 to 5V can be selected Terminal 4: 0 to 10V, 0 to 5V, 4 to 20mA can be selected	
		Digital Input	Entered from operation panel and parameter unit. Frequency setting increments is selectable.	
	Start Signal		Forward and reverse rotation or start signal automatic self-holding input (3-wire input) can be selected.	
	Input Signal		Five points. You can select from among multi-speed selection, remote setting, second function selection, terminal 4 input selection, JOG operation selection, PID control valid terminal, external thermal input, PU-external operation switchover, V/F switchover, output stop, start self-holding selection, forward rotation, reverse rotation command, inverter reset, PU-NET operation switchover, external-NET operation switchover, command source switchover, inverter operation enable signal, and PU operation external interlock	
	Operational Functions		Maximum/minimum frequency setting, frequency jump operation, external thermal relay input selection, automatic restart after instantaneous power failure operation, forward/reverse rotation prevention, remote setting, second function, multi-speed operation, regeneration avoidance, slip compensation, operation mode selection, offline auto tuning function, PID control, computer link operation (RS-485), Optimum excitation control, power failure stop, speed smoothing control, MODBUS-RTU	
	Output Signal	Output Signal Points	Open Collector Output	One point
			Relay Output	One point
		Operating Status		You can select from among inverter operation, up-to-frequency, overload alarm, output frequency detection, regenerative brake prealarm, electronic thermal relay function prealarm, inverter operation ready, output current detection, zero current detection, PID lower limit, PID upper limit, PID forward/reverse rotation output, fan alarm (*3), heatsink overheat pre-alarm, deceleration at an instantaneous power failure, PID control activated, PID output interruption, during retry, life alarm, current average value monitor, remote output, alarm output, fault output, fault output 3, and maintenance timer alarm
		For Meter Output Points	Analog Output	0 to 10VDC: one point
	For Meter		You can select from among output frequency, output current (steady), output voltage, frequency setting, converter output voltage, regenerative brake duty, electronic thermal relay function load factor, output current peak value, converter output voltage peak value, reference voltage output, motor load factor, PID set point, PID measured value, output power, PID deviation, motor thermal load factor, inverter thermal load factor 0 to 10VDC	
Indication	Operation Panel Parameter Unit (FR-PU07)	Operating Status	You can select from among output frequency, output current (steady), output voltage, frequency setting, cumulative energization time, actual operation time, converter output voltage, regenerative brake duty, electronic thermal relay function load factor, output current peak value, converter output voltage peak value, motor load factor, PID set point, PID measured value, PID deviation, inverter I/O terminal monitor, output power, cumulative power, motor thermal load factor, inverter thermal load factor, PTC thermistor resistance.	
		Fault Definition	Fault definition is displayed when the fault occurs and the past 8 fault definitions (output voltage/current/frequency/cumulative energization time right before the fault occurs) are stored	
	Additional Display By The Parameter Unit (FR-PU07) Only	Operating Status	Not used	
		Fault Definition	Output voltage/current/frequency/cumulative energization time immediately before the fault occurs	
Interactive Guidance		Function (help) for operation guide		
Protective Functions		Overcurrent during acceleration, overcurrent during constant speed, overcurrent during deceleration, overvoltage during acceleration, overvoltage during constant speed, overvoltage during deceleration, inverter protection thermal operation, motor protection thermal operation, heatsink overheat, input phase loss (*5, *6), output side earth (ground) fault overcurrent at start (*5), output phase loss, external thermal relay operation (*5), PTC thermistor operation (*5), parameter error, PU disconnection, retry count excess (*5), CPU fault, brake transistor alarm, inrush resistance overheat, analog input error, stall prevention operation, output current detection value exceeded (*5), safety circuit fault		
Warning Functions		Fan alarm (*3), overcurrent stall prevention, overvoltage stall prevention, PU stop, parameter write error, regenerative brake prealarm (*5), electronic thermal relay function prealarm, maintenance output (*5), undervoltage, operation panel lock, password locked, inverter reset, safety stop		
Environment	Surrounding Air Temperature		-10°C to +50°C (14°F to 122°F) (non-freezing) (*4)	
	Ambient Humidity		90%RH maximum (non-condensing)	
	Storage Temperature (*2)		-20°C to +65°C (-4°F to 149°F)	
	Atmosphere		Indoors (without corrosive gas, flammable gas, oil mist, dust and dirt, etc.)	
	Altitude/Vibration		Maximum 1000m (3280.80 feet) above sea level, 5.9m/s <sup>2</sup> or less at 10 to 55Hz (directions of X, Y, Z axes)	

### Notes:

- The braking torque indicated is a short-duration average torque (which varies with motor loss) when the motor alone is decelerated from 60Hz in the shortest time and is not a continuous regenerative torque. When the motor is decelerated from the frequency higher than the base frequency, the average deceleration torque will reduce. Since the inverter does not contain a brake resistor, use the optional brake resistor when regenerative energy is large. A brake unit (FR-BU2) may also be used.
- Temperatures applicable for a short time, e.g. in transit.
- As the FR-D720-042 or less, FR-D740-022 or less, FR-D720S-042 or less, FR-D710W-042 or less are not provided with the cooling fan, this alarm does not function.
- When using the inverters at the surrounding air temperature of 40°C (104°F) or less, the inverters can be installed closely attached (0cm clearance).
- This protective function does not function in the initial status.
- This protective function is available with the three-phase power input specification model only.

# FR-D700 Series Terminal Connection Diagram

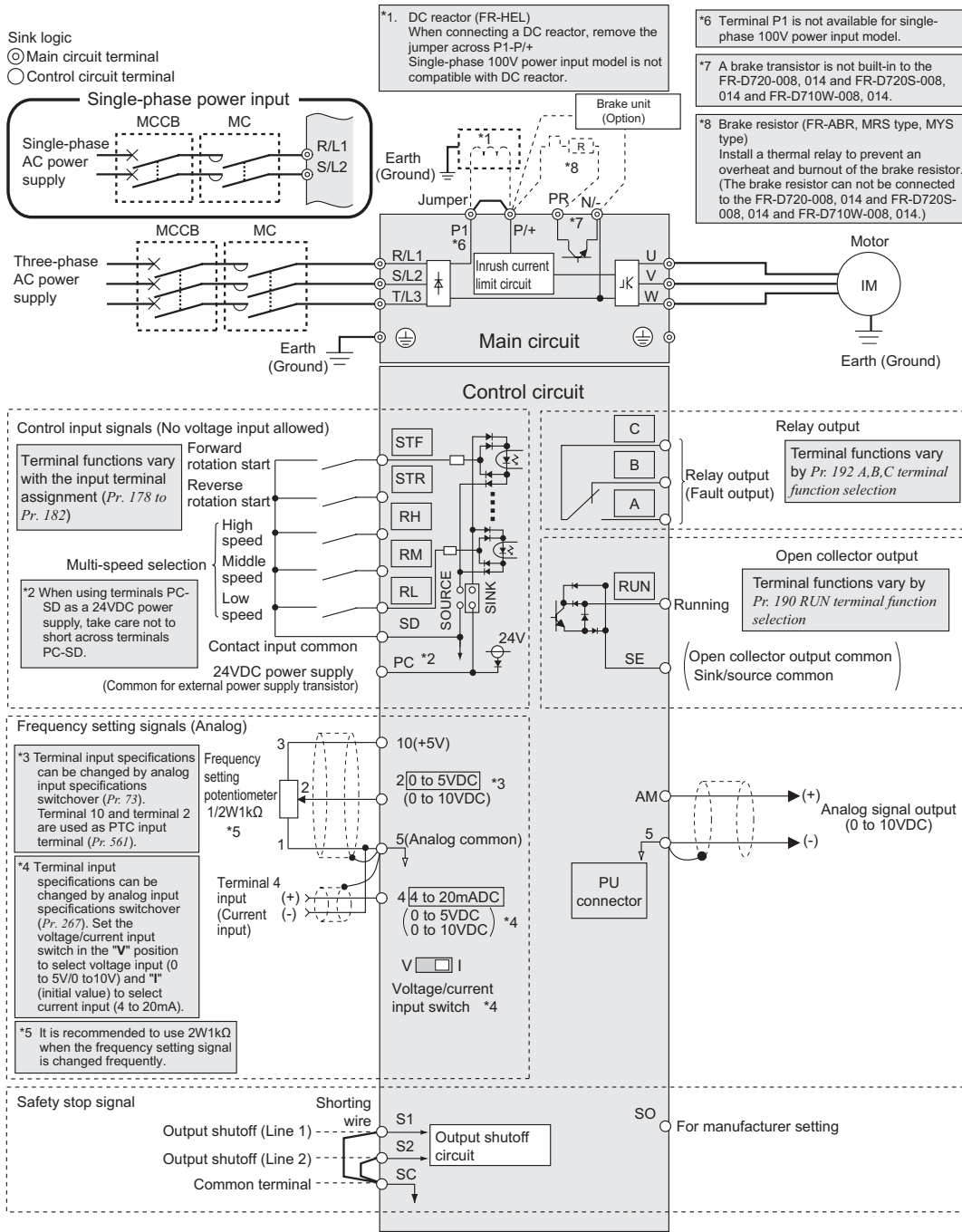

## Terminal Block Layout

Recommended wire size:  
 0.3mm<sup>2</sup> 0.75mm<sup>2</sup>

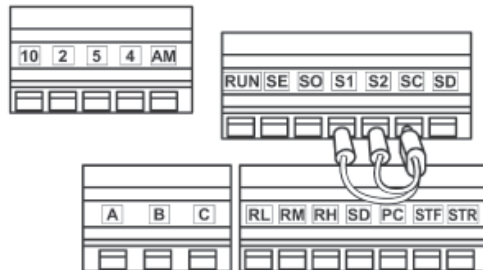

## FR-D700 Series Options

Model Number	Description	Notes	Stocked Item
FR-PU07	Alpha-Numeric multi-language keypad		S
FR-PU07BB	Battery back-up version of FR-PU07		S
D700-PT1	Adapter unit required for FR-PU07BB		S
FR-PA07	Panel mount basic keypad		S
FR-CONFIGURATOR	Programming and diagnostic software		S
SC-FRPC	Serial communications cable		S
FR-CB201	Remote cable for connecting keypad	1 meter cable	S
FR-CB203	Remote cable for connecting keypad	3 meter cable	S
FR-CB205	Remote cable for connecting keypad	5 meter cable	S
FR-ABR-__ K	External braking resistor		S
FR-RJ45-HUB4	Serial Network Hub - 2 Stations		-
FR-RJ45-HUB10	Serial Network Hub - 8 Stations		-
FR-RJ45-TR	Terminating Resistor for FR-RJ45-HUB		-

Note: \_\_ represents KW rating.

## Input Radio Noise Filter

This filter is connected to the input of the drive and helps to reduce radiated noise in the radio frequencies.

Drive Voltage	Kit Model Number	Leakage Current (mA)	Dimensions mm (in)			Stocked Item
			L	W	D	
208 - 230	FR-BIF	4	58 (2.3)	44 (1.8)	42 (1.7)	S
460	FR-BIF-H	4	58 (2.3)	44 (1.8)	42 (1.7)	-

## Line Noise Filter

Provides a toroid for line noise reduction.

Drive HP	Kit Model Number	Dimensions mm (in)			Stocked Item
		L	W	D	
0.5 - 5	FR-BSF01	110 (4.33)	22.5 (0.89)	65 (2.56)	S
0.5 - 75	FR-BLF	180 (7.07)	31.5 (1.24)	83 (3.27)	S

## FR-D700 EMC Filters

This attachment allows the VFD to be mounted onto the filter.

Model Number	Drive Model	Stocked Item
FFR-CS-050-14A-SF1	D720S-008 to 042	-
FFR-CS-080-20A-SF1	D720S-070	-
FFR-CS-110-26A-SF1	D720S-100	-
FFR-CSH-036-8A-SF1	D740-012 to 036	-
FFR-CSH-080-16ASF1	D740-050 to 080	-
FFR-MSH-170-30ASF1	D740-120 to 160	-

## DIN Rail Mounting Attachment

This attachment allows the D700 Series inverter to mount on a 35mm DIN rail.

Model Number	Drive Model				Stocked Item
	D710W	D720S	D720	D740	
FR-UDA01	008-025	008-042	008-042	-	S
FR-UDA02	042	070	070-100	012-080	S
FR-UDA03	-	-	165	-	-

## Brake Resistors

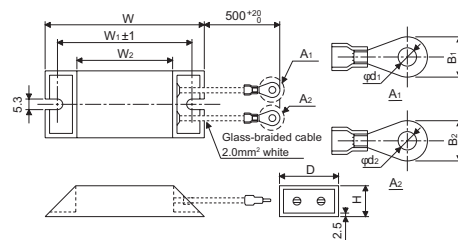

Brake Resistor Model	Dimensions (mm)				
	W	W1	W2	D	H
<b>200V Class</b>					
FR-ABR-0.4K	140	125	100	40	21
FR-ABR-0.75K	215	200	175	40	21
FR-ABR-2.2K	240	225	200	50	26
FR-ABR-3.7K	215	200	175	61	33
FR-ABR-5.5K	335	320	295	61	33
FR-ABR-7.5K	400	385	360	80	40
FR-ABR-11K	400	385	360	100	50
FR-ABR-15K (*1)	300	285	260	100	50
<b>400V Class</b>					
FR-ABR-H0.4K	115	100	75	40	21
FR-ABR-H0.75K	140	125	100	40	21
FR-ABR-H1.5K	215	200	175	40	21
FR-ABR-H2.2K	240	225	200	50	26
FR-ABR-H3.7K	215	200	175	61	33
FR-ABR-H5.5K	335	320	295	61	33
FR-ABR-H7.5K	400	385	360	80	40
FR-ABR-H11K	400	385	360	100	50
FR-ABR-H15K (*2)	300	285	260	100	50

Notes:

- For the 15K, connect the two supplied resistors (18 ohms) in parallel
- For the H15K, connect the two supplied resistors (18 ohms) in series.

## FR-D700 Conduit Kits

Kit Model Number	Description	Stocked Item
CK-5567	Conduit Kit for D720S-100	S
CK-27	Conduit Kit for D720S-042	S
CK-87	Conduit Kit for D720-238/318	S
CK-43-S	Conduit Kit for D720-070/100 / D740-012/036	S
CK-43-T	Conduit Kit for D710W-042 / D740-050/080	S

## FR-D700 Dynamic Braking

All Mitsubishi Electric VFDs have some inherent braking capability. During controlled deceleration, motor regenerative losses are dissipated in the motor, wire, and VFD circuitry. The built-in DC injection braking allows for low speed braking and stopping.

When the above capabilities are inadequate for an application, it is necessary to add a power transistor brake unit and resistor unit in series across the DC bus. Motor regeneration causes the DC bus voltage to increase, and when the voltage exceeds a specified threshold, the transistor turns on to pass current through the resistor. Motor kinetic energy is converted to heat energy. VFD overcurrent and overvoltage protective circuits are active at all times, and will fault-trip the VFD if the brake size is inadequate.

Two main factors must be considered when sizing the brake, the effective duty cycle (%ED) and the short time duty rating. The effective duty cycle is increased when an external resistor is added. It is preferable to profile the effective duty cycle of the units of time. With this information, the short time duty is known and the %ED can be calculated, as shown in the below example.

$$\%ED = \text{Braking time} / \text{total time for complete operating cycle} * 100$$

Example: Complete cycle is:

- 5 sec: Acceleration time to reach set speed
- 60 sec: Run time at set speed
- 3 sec: Deceleration time to come to a complete stop
- 12 sec: Time period motor remains stopped

$$\%ED = 3 / (5 + 60 + 3 + 12) * 100 = 3.6\%$$

The tables shown assume 100% brake torque, when brake torque is represented by its percentage to the rated torque of the applied motor.

$$\text{Torque (kg.m)} = 974 * \text{Power (kW)} / \text{Speed (rpm)}$$

### 240VAC Dynamic Braking Resistor at 100% Braking Torque

Resistor Kit Model Number	Weight kg (lbs)	Resistance (Ohms)	Continuous Permissible Power (W)	Motor (Hp)	Drive Model		Stocked Item
					D710W and D720(S)	% ED	
FR-ABR-0.4K	0.2 (0.5)	200	60	1/2	025	10%	S
FR-ABR-0.75K	0.4 (0.9)	100	80	1	042	10%	S
FR-ABR-2.2K	0.5 (1.1)	60	120	2 and 3	070 / 100	10%	S
FR-ABR-3.7K	0.8 (1.8)	40	155	5	165	10%	S
FR-ABR-5.5K	1.3 (2.9)	25	185	7 1/2	238	10%	S
FR-ABR-7.5K	2.2 (4.9)	20	340	10	318	10%	S

### 480VAC Dynamic Braking Resistor at 100% Braking Torque

Resistor Kit Model Number	Weight kg (lbs)	Resistance (Ohms)	Continuous Permissible Power (W)	Motor (Hp)	Drive Model		Stocked Item
					D740	% ED	
FR-ABR-H0.4K	0.2 (0.5)	1200	45	1/2	012	10%	S
FR-ABR-H0.75K	0.2 (0.5)	700	75	1	022	10%	S
FR-ABR-H1.5K	0.4 (0.9)	350	115	2	036	10%	S
FR-ABR-H2.2K	0.5 (1.1)	250	120	3	050	10%	S
FR-ABR-H3.7K	0.8 (1.8)	150	155	5	080	10%	S
FR-ABR-H5.5K	1.3 (2.9)	110	185	7 1/2	120	10%	S
FR-ABR-H7.5K	2.2 (4.9)	75	340	10	160	10%	S

## FR-D700 Heatsink Extension Kits

Kit Model Number	Model Number				Stocked Item
	FR-D710W-	FR-D720S-	FR-D720-	FR-D740-	
FR-E7CN-02	025	025	025	-	S
FR-E7CN-03	-	042	042	-	S
FR-E7CN-04	-	070	070/100	036 to 080	S
FR-E7CN-06	-	100	-	-	S
FR-E7CN-07	-	-	165	-	S
FR-E7CN-08	042	-	238/318	120/160	S
FR-E7CN-11	-	-	-	012/022	-

## FR-D700 Building Management Options

Network Type / Model		ETH-1000 (*2, *3)	XLTR-1000 (*2, *3)
Gateway Communication (*1)	BACnet®/IP	X	-
	EtherNet/IP™	X	-
	MODBUS® TCP	X	-
	PROFINET® IO	X	-
	BACnet® MS/TP	X	X
	Metasys® N2	X	X
Stocked Item		-	-

### Notes:

- For additional information, visit [www.iccdesigns.com](http://www.iccdesigns.com)
- Communication to multiple VFDs is possible
- Mounted and powered external to VFD

## FR-D700 Series Watt Loss and Efficiency Data

HP-CT	115VAC 1-Phase Input				240VAC 1-Phase Input				240VAC 3-Phase Input				480VAC 3-Phase Input			
	Model Number	Rated Watts	Watts Loss	Efficiency	Model Number	Rated Watts	Watts Loss	Efficiency	Model Number	Rated Watts	Watts Loss	Efficiency	Model Number	Rated Watts	Watts Loss	Efficiency
	FR-D710W-				FR-D720S-				FR-D720-				FR-D740-			
1/8	008	100	14	86%	008	100	14	86%	008	100	14	86%	-	-	-	-
1/4	015	200	20	90%	015	200	20	90%	014	200	20	90%	-	-	-	-
1/2	030	400	38	91%	030	400	32	92%	025	400	32	92%	012	400	40	90%
1	050	750	50	93%	050	750	50	93%	042	750	50	93%	022	750	55	93%
2	-	-	-	-	070	1500	80	95%	070	1500	80	95%	036	1500	90	94%
3	-	-	-	-	100	2200	110	95%	100	2200	100	95%	050	2200	100	95%
5	-	-	-	-	-	-	-	-	165	3700	160	96%	080	3700	180	95%
7.5	-	-	-	-	-	-	-	-	238	5500	270	95%	120	5500	240	96%
10	-	-	-	-	-	-	-	-	318	7500	360	95%	160	7500	280	96%

### General Notes:

- The amount of heat generated by the inverter is based on one inverter connected to one motor of the same capacity.
- The amount of heat generated in the above table is the amount of heat generated when the inverter is operated at its rated current.
- The amount of heat generated will decrease according to the motor load and usage (duty).

## FR-D700 Standby Power

HP-CT	115VAC 1-Phase Input			240VAC 1-Phase Input			240VAC 3-Phase Input			480VAC 3-Phase Input		
	Model Number	Stand-By Power Consumption		Model Number	Stand-By Power Consumption		Model Number	Stand-By Power Consumption		Model Number	Stand-By Power Consumption	
	FR-D710W-	Min	Max	FR-D720S-	Min	Max	FR-D720-	Min	Max	FR-D740-	Min	Max
1/8	008	5.5	10.5	008	5.5	10.5	008	5.5	10.5	-	-	-
1/4	015	5.5	10.5	015	5.5	10.5	014	5.5	10.5	-	-	-
1/2	030	5.5	10.5	030	5.5	10.5	025	5.5	10.5	012	10.5	15
1	050	5.5	10.5	050	5.5	10.5	042	5.5	10.5	022	10.5	15
2	-	-	-	070	5.5	14	070	5.5	14	036	10.5	17
3	-	-	-	100	5.5	14	100	5.5	14	050	10.5	17
5	-	-	-	-	-	-	165	6	15	080	10.5	17
7.5	-	-	-	-	-	-	238	13	22.5	120	13.5	22.5
10	-	-	-	-	-	-	318	13	22.5	160	13.5	22.5

### General Notes:

- The maximum is generated with PC terminal operating 100mA load, external parameter unit, and cooling fan operating.
- The minimum is generated with no load on PC terminal, no external parameter unit, and cooling fan off.