

FR-F800-E Series

The FR-F800-E is a pump and fan control VFD that combines performance, accuracy and reliability with embedded Ethernet based communications to enhance overall system flexibility. With 100Mbps Ethernet TCP/IP and BACnet/IP connectivity as the standard, the FR-F800-E provides an increased ability for remote system monitoring, parameter adjustments and easy integration into an existing network environments.

- **NEMA 1 / UL-1 Rated:** FR-F800 is Plenum-Rated and can be mounted as a stand-alone unit when required – no need to provide a separate enclosure*
- **Ethernet Communications as Standard:** Communicate with MODBUS TCP/IP or CC-Link IE Field Basic communications networks at a speed of 100Mbps without the need for an extra option card.
- **Built-in Filter:** Limits the effects of radio noise on sensitive equipment
- **Drive to Drive Communications:** Utilize the internal PLC to communicate without a master PLC controller allowing the drives to work together as a team
- **Optimum Excitation Control:** FR-F800 uses vector drive technology to calculate motor load and ensures maximum energy savings, even if motor loading changes
- **3 Programmable Skip Frequencies:** Avoid points of mechanical resonance in ducting and pipework
- **Drive Settings can be Uploaded or Downloaded:** Using a standard USB memory stick
- **Real-time Clock:** Drive trip messages are 'time stamped' for diagnostic purposes**
- **Bi-Directional Coasting Motor Restart:** FR-F800 can safely 'catch' and control a motor which is already spinning (in either direction) on start-up.
- **Advanced PID Control Features:**
 - 2 Independent PID loops
 - Pre-Charge Mode
 - Sleep Mode
 - Multiple Motor control (up to 4)
 - Selectable response to 'loss of signal'
- Control of high efficiency IPM motors
- **Advanced Power Monitoring Capability:** Including pulse train output
- **UL-Approved Rating:** For single phase operation
- **Out-of-Range Warning System:** Detects broken drive belts and other potential mechanical problems
- **Automatic IP Address Detection:** Automatically detect the IP address of all connected drives, quickly enabling connection and programming using FR-Configurator software
- **Remote Operation:** Communicate with a drive remotely for commissioning, monitoring or troubleshooting anytime from anywhere



Notes
 * Drive Sizes up to 40HP
 ** Requires the use of the FR-LU08 keypad

FR-F8 [1] 0- [2] [3] [4]

1 Max Load Capacity

Symbol	Voltage Class
2	200V class
4	400V class

2 Voltage

Symbol	Voltage Class
1100023 to 068301	Inverter SLD rated current (A)
0.75 to 315K	Inverter LD rated capacity (kW)

3 Communication

Symbol	Type (*1)	Communication Type
E1	FM	Ethernet (*2)
E2	CA	

4 Circuit Board

Symbol	Circuit Board Coating (conforming to IEC60721-3-3 3C2/3S2)	Plated Conductor
None	Without	Without
60	With	Without
06 (*3)	With	With

1. Specification differs by the type. Major differences are shown in the table below.
 2. Inverter equipped with a built-in Ethernet board (FR-A8ETH).
 3. Applicable for the FR-F820-00340(7.5K) or higher, and the FR-F840-00170(7.5K) or higher.

Type	Monitor output	Initial Setting				
		Built-in EMC Filter	Control Logic	Rated Frequency	Pr.19 Base Frequency Voltage	Pr.570 Multiple Rating Setting
FM (terminal FM equipped model)	Terminal FM: pulse train output Terminal AM: analog voltage output (0 to 10 VDC)	OFF	Sink logic	60 Hz	9999 (same as the power supply voltage)	1 (LD rating)
CA (terminal CA equipped model)	Terminal CA: analog current output (0 to 20 mADC) Terminal AM: analog voltage output (0 to 10 VDC)	ON	Source logic	50 Hz	8888 (95% of the power supply voltage)	0 (SLD rating)

FR-F800 Ratings, 240V Class

Model Number	AMPS for Duty		HP For Duty (NEC)		Frame Size	Weight (lbs)	Cooling Method	Protective Rating	Stocked Item
	SLD	LD	SLD	LD					
FR-F820-00046-E3N6	4.6	4.2	1	1	A	6	Self-Cooling	UL Type 1- Plenum Rated	S
FR-F820-00077-E3N6	7.7	7	2	2	B	6			S
FR-F820-00105-E3N6	10.5	9.6	3	3	C	9			S
FR-F820-00167-E3N6	16.7	15.2	5	5	C	9	S		
FR-F820-00250-E3N6	25	23	7.5	7.5	C	9	S		
FR-F820-00340-E3N6	34	31	10	10	D	17	S		
FR-F820-00490-E3N6	49	45	20	15	D	17	S		
FR-F820-00630-E3N6	63	58	20	20	E	20	S		
FR-F820-00770-E3N6	77	70.5	25	25	F	37	S		
FR-F820-00930-E3N6	93	85	30	30	F	37	S		
FR-F820-01250-E3N6	125	114	40	40	F	37	S		
FR-F820-01540-E360	154	140	60	50	G	48	Forced Air Cooling		S
FR-F820-01870-E360	187	170	60	60	H	92			S
FR-F820-02330-E360	233	212	75	75	H	92			S
FR-F820-03160-E360	316	288	125	100	K	119			S
FR-F820-03800-E3U6	380	346	150	125	L	163		S	
FR-F820-04750-E3U6	475	432	150	150	L	163		-	
								IP00	S
									S
									S

Note: Drives in Shaded Area MUST be used together with FR-HEL DC Link Choke (sold separately).
 SLD - 110% 60s, 120% 3s (inverse-time characteristics) at ambient temperature of 40°C.
 LD - 120% 60s, 150% 3s (inverse-time characteristics) at ambient temperature of 50°C.

FR-HEL DC Link Chokes (sold separately)

Model Number	LD	SLD
FR-F820-03160-E360	FR-HEL-75K	FR-HEL-90K
FR-F820-03800-E3U6	FR-HEL-90K	FR-HEL-110K
FR-F820-04750-E3U6	FR-HEL-110K	FR-HEL-110K

FR-F800-E Ratings, 480V Class

Model Number	AMPS for Duty		HP For Duty (NEC)		Frame Size	Weight (lbs) (*1)	Cooling Method	Protective Rating	Stocked Item
	SLD	LD	SLD	LD					
FR-F840-00023-E3N6	2.3	2.1	1	1	C	8	Self - Cooling	UL Type 1 - Plenum Rated	S
FR-F840-00038-E3N6	3.8	3	2	2	C	8			S
FR-F840-00052-E3N6	5.2	4.8	3	3	C	8			S
FR-F840-00083-E3N6	8.3	7.6	5	5	C	9			S
FR-F840-00126-E3N6	12.6	11.5	7.5	7.5	C	9			S
FR-F840-00170-E3N6	17	16	10	10	D	17			S
FR-F840-00250-E3N6	25	23	15	15	D	17			S
FR-F840-00310-E3N6	31	29	20	20	E	20			S
FR-F840-00380-E3N6	38	35	25	25	E	20			S
FR-F840-00470-E3N6	47	43	30	30	F	37	S		
FR-F840-00620-E3N6	62	57	40	40	F	37	S		
FR-F840-00770-E360	77	70	60	50	G	51	Forced Air Cooling		S
FR-F840-00930-E360	93	85	60	60	H	90			S
FR-F840-01160-E360	116	106	75	75	H	90			S
FR-F840-01800-E360	180	144	150	100	H	95			S
FR-F840-02160-E3U6	216	180	150	150	J	114		S	
FR-F840-02600-E3U6	260	216	200	150	J	121		S	
FR-F840-03250-E3U6	325	260	250	200	L	156		S	
FR-F840-03610-E3U6	361	325	300	250	L	172		S	
FR-F840-04320-E3U6	432	361	350	300	M	257		S	
FR-F840-04810-E3U6	481	432	400	350	M	257		S	
FR-F840-05470-E3U6	547	481	450	400	N	365		S	
FR-F840-06100-E3U6	610	547	500	450	N	365		S	
FR-F840-06830-E3U6	683	610	550	500	N	365		S	

Note 1: Weights of the drive and the CC2 modules are COMBINED. Drives in Shaded Area MUST be used together with FR-HEL-H DC Link Choke (sold separately)

480V FR-HEL-H DC Link Chokes (sold separately)

Model Number	LD	SLD
FR-F840-01800-E360	FR-HEL-H75K	FR-HEL-H90K
FR-F840-02160-E3U6	FR-HEL-H90K	FR-HEL-H110K
FR-F840-02600-E3U6	FR-HEL-H110K	FR-HEL-H132K
FR-F840-03250-E3U6	FR-HEL-H132K	FR-HEL-H160K
FR-F840-03610-E3U6	FR-HEL-H160K	FR-HEL-H185K
FR-F840-04320-E3U6	FR-HEL-H185K	FR-HEL-H220K
FR-F840-04810-E3U6	FR-HEL-H220K	FR-HEL-H250K
FR-F840-05470-E3U6	FR-HEL-H250K	FR-HEL-H280K
FR-F840-06100-E3U6	FR-HEL-H280K	FR-HEL-H315K
FR-F840-06830-E3U6	FR-HEL-H315K	FR-HEL-H355K

Model Number	AMPS for Duty		HP For Duty (NEC)		Frame Size	Weight (lbs) (*1)	Cooling Method	Protective Rating	Stocked Item
	SLD	LD	SLD	LD					
FR-F842-07700-E3U6 + FR-CC2-H355K-60	-	683	-	550	P+R	827	Forced Air Cooling	IP00	S
FR-F842-07700-E3U6 + FR-CC2-H400K-60	770	-	650	-	P+S	979			S
FR-F842-08660-E3U6 + FR-CC2-H400K-60	-	770	-	650	P+S	979			S
FR-F842-08660-E3U6 + FR-CC2-H450K-60	866	-	700	-	P+S	986			S
FR-F842-09620-E3U6 + FR-CC2-H450K-60	-	866	-	700	Q+S	1162			S
FR-F842-09620-E3U6 + FR-CC2-H500K-60	962	-	800	-	Q+S	1168			S
FR-F842-10940-E3U6 + FR-CC2-H500K-60	-	962	-	800	Q+S	1168			S
FR-F842-10940-E3U6 + FR-CC2-H560K-60	1094	-	900	-	Q+S	1168			S
FR-F842-12120-E3U6 + FR-CC2-H560K-60	-	1094	-	900	Q+S	1168			S
FR-F842-12120-E3U6 + FR-CC2-H630K-60	1212	-	1000	-	Q+S	1168			S

Note: Weights of the drive and the CC2 modules are COMBINED. Drives in Shaded Area MUST be used together with FR-HEL-H DC Link Choke (sold separately).

SLD- 110% 60s, 120% 3s (inverse-time characteristics) at ambient temperature of 40°C

LD- 120% 60s, 150% 3s (inverse-time characteristics) at ambient temperature of 50°C

Always install the FR-CC2-H converter unit (not required when the FR-HC2 high power factor converter is used)

FR-F800-E Ratings, 600V Class

Model Number (*3)	AMPS for Duty		Horsepower for Duty (NEC)		Frame Size	Weight (lbs)	Cooling Method	Protective Rating	Stocked Item
	SLD	LD	SLD	LD					
FR-F860-00027-E3N6	2.7	2.5	2	1.5	C	11.7	Self Cooling	Enclosed Type (UL-1 plenum rated)	S
FR-F860-00061-E3N6	6.1	5.6	5	3	C	12.8	S		
FR-F860-00090-E3N6	9	8.2	7.5	5	C	12.8	S		
FR-F860-00170-E3N6	17	16	15	10	D	15.4	S		
FR-F860-00320-E3N6	32	27	30	25	E	19.8	S		
FR-F860-00450-E3N6	45	41	40	40	F	37.4	S		
FR-F860-00680-E360	68	62	60	60	H	79.2	S		
FR-F860-01080-E360 (*1)	108	99	100	100	H	90.2	S		
FR-F860-01440-E360 (*1)	144	131	150	125	J	114	S		
FR-F860-01670-E360 (*1)	167	152	150	150	J	114	S		
FR-F860-02430-E360 (*1)	243	221	250	200	J	121	Forced Air Cooling	Open Type (IP00)	S
FR-F860-02890-E360 (*1)	289	255	300	250	M	246	S		
FR-F860-03360-E360 (*1)	336	304	350	300	M	253	S		
FR-F860-04420-E360 (*1)	442	402	450	400	N	337	S		
FR-F862-05450-E360 + FR-CC2-C355K-60 (*2)	545	496	550	500	P+R	810	S		
FR-F862-06470-E360 + FR-CC2-C400K-60 (*2)	647	589	650	600	Q+S	920	S		
FR-F862-08500-E360 + FR-CC2-C560K-60 (*2)	850	773	850	750	Q+S	1126	S		

Notes:

1. These drives MUST be used with a DC Link Choke (sold separately).
2. FR-F862 Drives are inverter stage only; use together with FR-CC2-C rectifier stage. Maximum Input and Output Current of FR-CC2 modules is the value shown. COMBINED weight shown.
3. The FR-F860 does not include a built-in parameter unit. The FR-DU08 or FR-LU08 is sold separately.

600V FR-HEL-C DC Link Chokes (sold separately)

Model Number	SLD	LD
FR-F860-01080-E360	FR-HEL-C75K	FR-HEL-C75K
FR-F860-01440-E360	FR-HEL-C90K	FR-HEL-C90K
FR-F860-01670-E360	FR-HEL-C110K	FR-HEL-C110K
FR-F860-02430-E360	FR-HEL-C185K	FR-HEL-C132K
FR-F860-02890-E360	FR-HEL-C220K	FR-HEL-C185K
FR-F860-03360-E360	FR-HEL-C280K	FR-HEL-C220K
FR-F860-04420-E360	FR-HEL-C280K	FR-HEL-C280K

FR-F800-E General Specifications

Operation Specifications	Control Method		Soft-PWM control, high carrier frequency PWM control (selectable among V/F control (Optimum excitation control), Advanced magnetic flux vector control (Advanced optimum excitation control) and PM motor control)
	Output Frequency Range		0.2 to 590 Hz (The upper-limit frequency is 400 Hz under Advanced magnetic flux vector control, and PM motor control)
	Frequency Setting Resolution	Analog Input	0.015 Hz/60 Hz (terminal 2, 4: 0 to 10 V/12 bits) 0.03 Hz/60 Hz (0 to 5 V/11 bits or 0 to 20 mA/approx. 11 bits for terminals 2 and 4, 0 to ±10 V/12 bits for terminal 1) 0.06 Hz/60 Hz (0 to ±5 V/11 bits for terminal 1)
		Digital Input	0.01Hz
	Frequency Accuracy	Analog Input	Within ±0.2% of the max. output frequency (25°C ±10°C)
		Digital Input	Within 0.01% of the set output frequency
	Voltage / Frequency Characteristics		Base frequency can be set from 0 to 590 Hz. Constant-torque/variable-torque pattern or adjustable 5 points V/F can be selected.
	Starting Torque	Induction Motor	120% 0.5 Hz (Advanced magnetic flux vector control)
		IPM Motor	50%
	Torque Boost		Manual torque boost
	Acceleration / Deceleration Time Setting		0 to 3600 s (acceleration and deceleration can be set individually), linear or S-pattern acceleration/deceleration mode, backlash countermeasures acceleration/deceleration can be selected.
	DC Injection Brake (Induction Motor)		Operation frequency (0 to 120 Hz), operation time (0 to 10 s), operation voltage (0 to 30%) variable
	Stall Prevention Operation Level		Activation range of stall prevention operation (SLD rating: 0 to 120%, LD rating: 0 to 150%). Whether to use the stall prevention or not can be selected. (V/F control, Advanced magnetic flux vector control)
	Frequency Setting Signal	Analog Input	Terminals 2 and 4: 0 to 10 V, 0 to 5 V, 4 to 20 mA (0 to 20 mA) are available. Terminal 1: -10 to +10 V, -5 to 5 V are available.
		Digital Input	Input using the setting dial of the operation panel or the parameter unit. Four-digit BCD or 16-bit binary (when used with option FR-A8AX)
Start Signal		Forward and reverse rotation or start signal automatic self-holding input (3-wire input) can be selected.	
Input Signal		Low-speed operation command, Middle-speed operation command, High-speed operation command, Second function selection, Terminal 4 input selection, Jog operation selection, Output stop, Start self-holding selection, Forward rotation command, Reverse rotation command, Inverter reset The input signal can be changed using Pr.178 to Pr.189 (Input terminal function selection).	
Pulse Train Input		100kpps	
Operational Functions		Maximum and minimum frequency settings, multi-speed operation, acceleration/deceleration pattern, thermal protection, DC injection brake, starting frequency, JOG operation, output stop (MRS), stall prevention, regeneration avoidance, increased magnetic excitation deceleration, DC feeding (*1), frequency jump, rotation display, automatic restart after instantaneous power failure, electronic bypass sequence, remote setting, retry function, carrier frequency selection, fast response current limit, forward/reverse rotation prevention, operation mode selection, slip compensation, speed smoothing control, traverse, auto tuning, applied motor selection, RS-485 communication, Ethernet communication, PID control, PID pre-charge function, cooling fan operation selection, stop selection (deceleration stop/coasting), power-failure deceleration stop function, PLC function, life diagnosis, maintenance timer, current average monitor, multiple rating, test run, 24 V power supply input for control circuit, safety stop function, self power management, BACnet communication, PID gain tuning, cleaning, load characteristics storage, emergency drive (*1)	
Output Signals	Open Collector Output (Five Terminals) Relay Output (Two Terminals)	Inverter running, Up to frequency, Instantaneous power failure/undervoltage (*1), Overload warning, Output frequency detection, Fault. The output signal can be changed using Pr.190 to Pr.196 (Output terminal function selection). Fault codes of the inverter can be output (4 bits) from the open collector.	
	Pulse Train Output (FM Type)	50 kpps	
Indication	For Meter	Pulse Train Output (FM Type)	Max. 2.4 kHz: one terminal (output frequency) The monitored item can be changed using Pr.54 FM/CA terminal function selection.
		Current Output (CA Type)	Max. 20 mADC: one terminal (output frequency) The monitored item can be changed using Pr.54 FM/CA terminal function selection.
		Voltage Output	Max. 10 VDC: one terminal (output frequency) The monitored item can be changed using Pr.158 AM terminal function selection.
Operation Panel (FR-DU08)	Operating Status	Output frequency, output current, output voltage, frequency setting value The monitored item can be changed using Pr.52 Operation panel main monitor selection.	
	Fault Record	Fault record is displayed when a fault occurs. Past 8 fault records and the conditions immediately before the fault (output voltage/current/frequency/cumulative energization time/year/month/date/time) are saved.	
Protective / Warning Function		Overcurrent trip during acceleration, Overcurrent trip during constant speed, Overcurrent trip during deceleration or stop, Regenerative overvoltage trip during acceleration, Regenerative overvoltage trip during constant speed, Regenerative overvoltage trip during deceleration or stop, Inverter overload trip (electronic thermal relay function), Motor overload trip (electronic thermal relay function), Heatsink overheat, Instantaneous power failure (*1) Undervoltage (*1), Input phase loss (*1, *2), Stall prevention stop, Loss of synchronism detection (*2), Upper limit fault detection, Lower limit fault detection, Brake transistor alarm detection(*1), Output side earth (ground) fault overcurrent, Output short circuit, Output phase loss, External thermal relay operation (*2), PTC thermistor operation (*2), Option fault, Communication option fault, Parameter storage device fault, PU disconnection, Retry count excess (*2), CPU fault, Operation panel power supply short circuit, 24 VDC power fault, Abnormal output current detection (*2), Inrush current limit circuit fault (*1) Ethernet communication fault (*2), Analog input fault, USB communication fault, Safety circuit fault, Overspeed occurrence (*2), 4 mA input fault (*2), Pre-charge fault (*2), PID signal fault (*2), Internal circuit fault, User definition error in the PLC function. Fan alarm, Stall prevention (overcurrent), Stall prevention (overvoltage), Regenerative brake pre-alarm (*1, *2), Electronic thermal relay function pre-alarm, PU stop, Parameter copy, Safety stop, Maintenance timer 1 to 3 (*2), USB host error, Operation panel lock (*2), Password locked (*2), Parameter write error, Copy operation error, 24 V external power supply operation, Load fault warning, Emergency drive in operation (*1), Continuous operation during communication fault, Ethernet communication fault	
Environment	Ambient Temperature		-10°C to +50°C (non-freezing) (LD rating) -10°C to +40°C (non-freezing) (SLD rating)
	Ambient Humidity		With circuit board coating (conforming to IEC60721-3-3 3C2/3S2): 95% RH or less (non-condensing) Without circuit board coating: 90% RH or less (non-condensing)
	Storage Temperature (*3)		-20°C to +65°C
	Atmosphere		Indoors (without corrosive gas, flammable gas, oil mist, dust and dirt, etc.)
	Altitude / Vibration		Maximum 1000 m above sea level (*4), 5.9 m/s ² or less (*5) at 10 to 55 Hz (directions of X, Y, Z axes)

Notes:

1. Available only for the standard model.
2. This protective function is not available in the initial status.
3. Temperature applicable for a short time, e.g. in transit.
4. For the installation at an altitude above 1,000 m (up to 2,500 m), derate the rated current 3% per 500 m.
5. 2.9 m/s² or less for the FR-F840-04320(185K) or higher.

FR-F800 Series Terminal Connection Diagram (Version with 0-20mA Analog Output Signal) CA Type

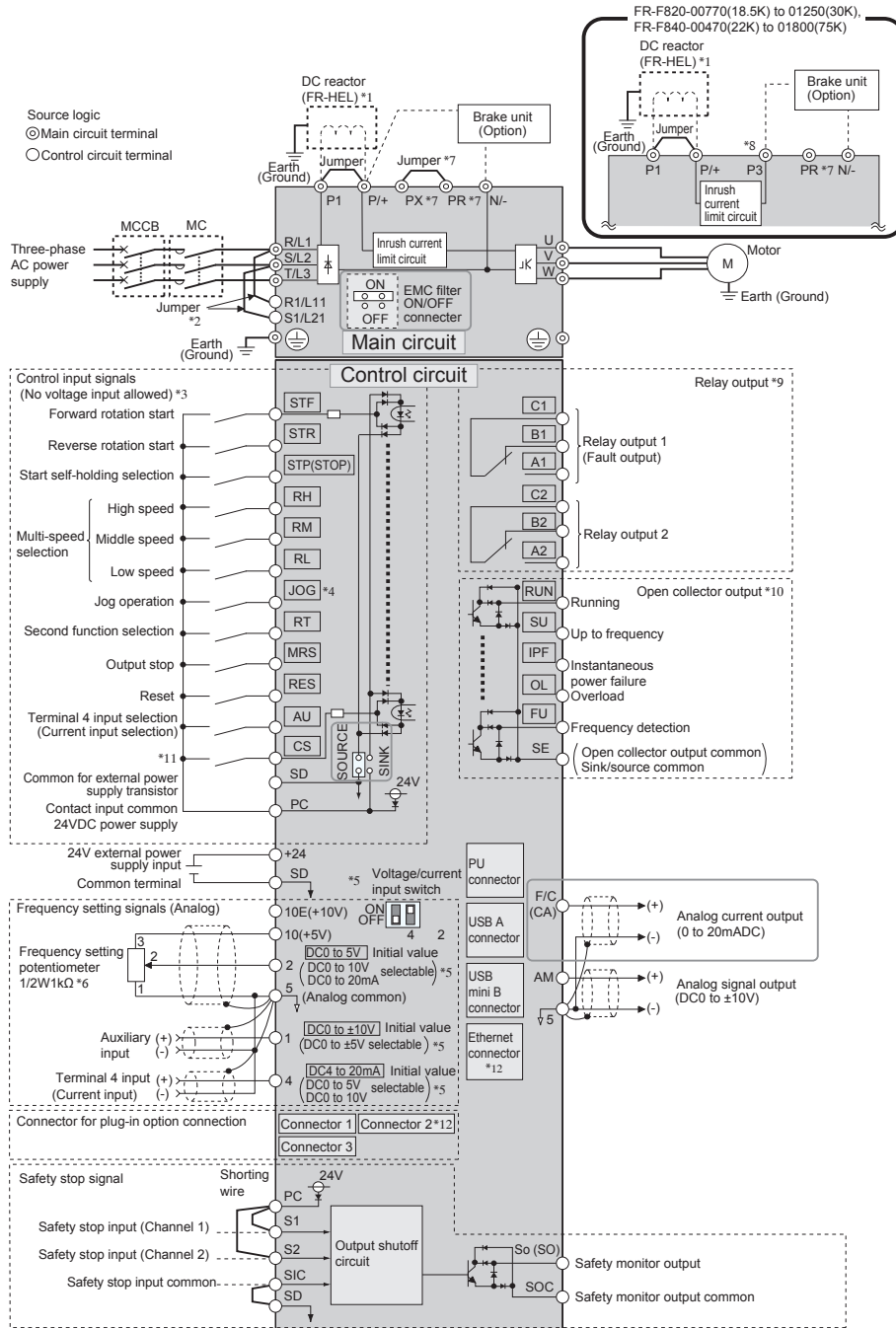

Notes:

- For the FR-F820-03160(75K) or higher, the FR-F840-01800(75K) or higher, always connect a DC reactor (FR-HEL), which is available as an option. (To select a DC reactor, refer to the User Guide, and select one according to the applicable motor capacity.) When a DC reactor is connected to the FR-F820-02330(55K) or lower or the FR-F840-01160(55K) or lower, if a jumper is installed across terminals P1 and P+, remove the jumper before installing the DC reactor.
- When using separate power supply for the control circuit, remove the jumper between R1/L11 and S1/L21.
- The function of these terminals can be changed with the input terminal assignment (Pr.178 to Pr.189).
- Terminal JOG is also used as the pulse train input terminal. Use Pr.291 to choose JOG or pulse.
- Terminal input specifications can be changed by analog input specification switchover (Pr.73, Pr.267). To input a voltage, set the voltage/current input switch OFF. To input a current, set the voltage/current input switch ON. Terminals 10 and 2 are also used as a PTC input terminal. (Pr.561) (Refer to the FR-F800 Instruction Manual (Detailed).)
- It is recommended to use 2 W 1 kΩ when the frequency setting signal is changed frequently.
- Do not use terminals PR and PX. The jumper may or may not be attached depending on the inverter.
- Do not connect the DC power supply (under DC feeding mode) to terminal P3.
- The function of these terminals can be changed with the output terminal assignment (Pr.195, Pr.196).
- The function of these terminals can be changed with the output terminal assignment (Pr.190 to Pr.194).
- No function is assigned in the initial status. Assign the function using Pr.186 CS terminal function selection.
- The option connector 2 cannot be used because the Ethernet board is installed in the initial status. The Ethernet board must be removed to install a plug-in option to the option connector 2. (However, Ethernet communication is disabled in that case.)

ADDITIONAL NOTES:

- To prevent a malfunction due to noise, keep the signal cables 10 cm or more away from the power cables. Also, separate the main circuit cables at the input side from the main circuit cables at the output side.
- After wiring, wire offcuts must not be left in the inverter. Wire offcuts can cause an alarm, failure or malfunction. Always keep the inverter clean. When drilling mounting holes in an enclosure etc., take caution not to allow chips and other foreign matter to enter the inverter.
- Set the voltage/current input switch correctly. Incorrect setting may cause a fault, failure or malfunction.

FR-F802 Series Terminal Connection Diagram (Version with 0-20mA Analog Output Signal)

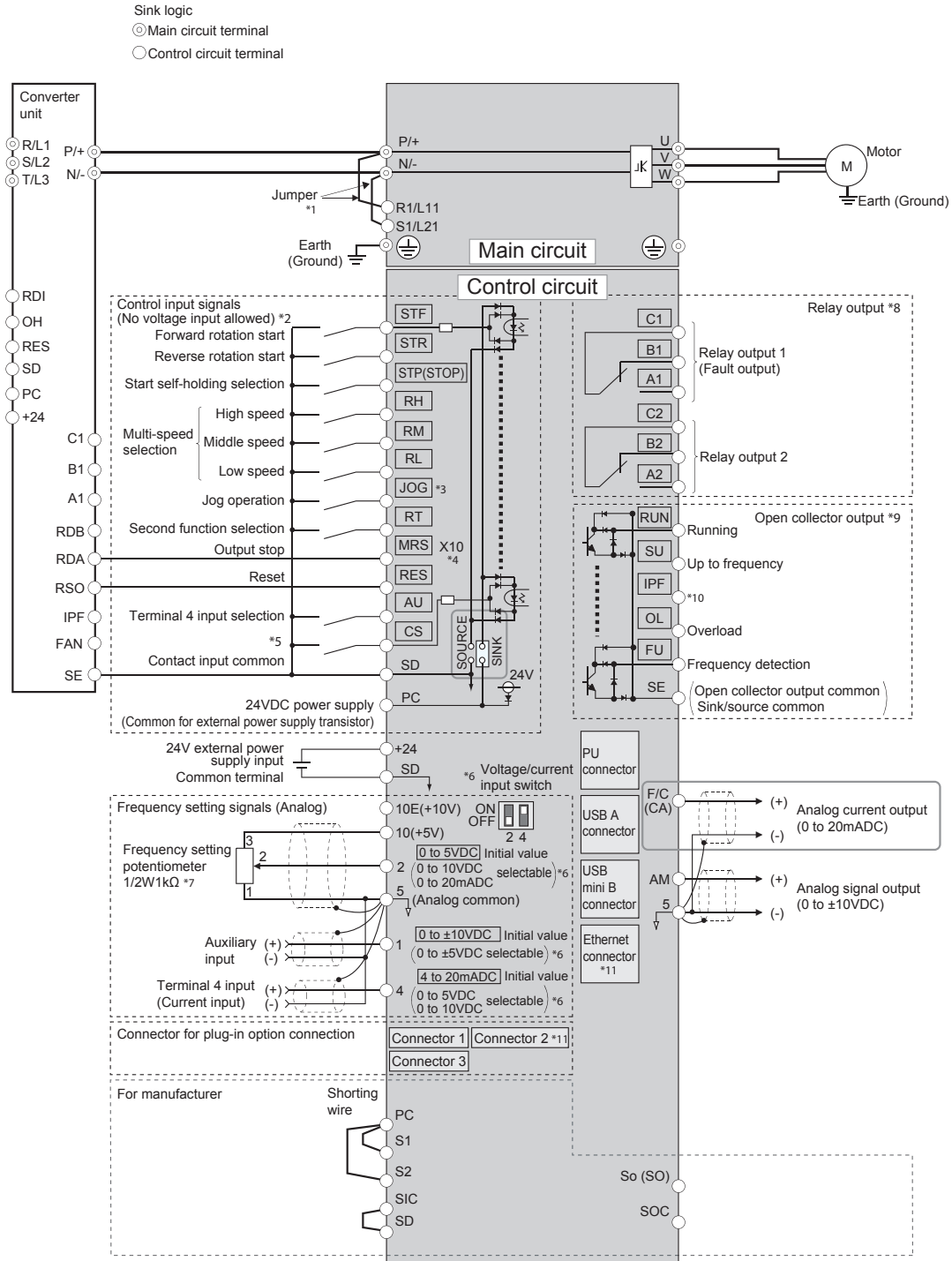

Notes:

- Terminals R1/L11 and S1/L21 are connected to terminals P/+ and N/- with a jumper respectively. When using separate power supply for the control circuit, remove the jumpers from R1/L11 and S1/L21.
- The function of these terminals can be changed with the input terminal assignment (Pr.178 to Pr.189).
- Terminal JOG is also used as the pulse train input terminal. Use Pr.291 to choose JOG or pulse.
- The X10 signal (NC contact input specification) is assigned to the terminal MRS in the initial setting. Set Pr.599 = "0" to change the input specification of the X10 signal to NO contact.
- No function is assigned in the initial setting. Use Pr.186 for function assignment.
- Terminal input specifications can be changed by analog input specification switchover (Pr.73, Pr.267). To input a voltage (0 to 5 V/0 to 10 V), set the voltage/current input switch OFF. To input a current (4 to 20 mA), set the voltage/current input switch ON. Terminals 10 and 2 are also used as a PTC input terminal. (Pr.561)
- It is recommended to use 2 W 1 kΩ when the frequency setting signal is changed frequently.
- The function of these terminals can be changed with the output terminal assignment (Pr.195, Pr.196).
- The function of these terminals can be changed with the output terminal assignment (Pr.190 to Pr.194).
- No function is assigned in the initial setting. Use Pr.192 for function assignment.
- The option connector 2 cannot be used because the Ethernet board is installed in the initial status. The Ethernet board must be removed to install a plug-in option to the option connector 2. (However, Ethernet communication is disabled in that case.)

ADDITIONAL NOTES

- To prevent a malfunction due to noise, keep the signal cables 10 cm or more away from the power cables. Also, separate the main circuit cables at the input side from the main circuit cables at the output side.
- After wiring, wire offcuts must not be left in the inverter. Wire offcuts can cause an alarm, failure or malfunction. Always keep the inverter clean. When drilling mounting holes in an enclosure etc., take caution not to allow chips and other foreign matter to enter the inverter.
- Set the voltage/current input switch correctly. Incorrect setting may cause a fault, failure or malfunction.
- Terminals S1, S2, SIC, So (SD), and SOC are for manufacturer setting. Do not remove the shorting wires across terminals S1 and PC, terminals S2 and PC, and terminals SIC and SD. When the shorting wires are removed, the inverter does not operate.

FR-F800-E Dimensions – Frame Size Key Dimensions, 230V and 480V Drives

Series		Height in (mm)	Width in (mm)	Depth in (mm)
FR-F800	A	12.2 (310)	4.33 (110)	4.39 (112)
	B	12.2 (310)	4.33 (110)	4.98 (127)
	C	12.52 (318)	5.91 (150)	5.57 (141.6)
	D	12.76 (324)	8.66 (220)	6.69 (170)
	E	14.29 (363)	8.66 (220)	7.48 (190)
	F	20.37 (517)	9.84 (250)	7.48 (190)
	G	21.67 (550)	12.80 (325)	7.68 (195)
	H	21.67 (550)	17.13 (435)	9.84 (250)
	J	24.41 (620)	18.31 (465)	11.81 (300)
	K	27.56 (700)	18.31 (465)	9.84 (250)
	L	29.13 (740)	18.31 (465)	14.17 (360)
	M	39.76 (1010)	19.61 (498)	14.96 (380)
	N	39.76 (1010)	26.77 (680)	14.96 (380)

Series		Height in (mm)	Width in (mm)	Depth in (mm)
FR-F842	P	52.4 (1330)	21.3 (540)	17.3 (440)
	Q	62.2 (1580)	26.8 (680)	17.3 (440)
FR-CC2-H	R	52.4 (1330)	23.6 (600)	17.3 (440)
	S	62.2 (1580)	23.6 (600)	17.3 (440)

FR-F800-E Series Options and Accessories

Model Number	Description	Comments	Stocked Item
FR-A8AX	16 Bit Digital Input Card	BCD or Binary input	S
FR-A8AY	Digital Output / Extended Analog Output Card	2 extra 0-20 mA or 0-10V output signals	S
FR-A8AR	Relay Output Card	3 extra independent type 'C' relays	S
FR-A8ERS-60	A/F800 Series RS485 Option Card		S
FR-A8AC	A/F800 120V Control Option		S
FR-A8AN	A/F800 4-20mA I/O Card		S
FR-A8NL	A/F800 Series LONWorks Communication Card		S
FR-A8NC	CC-Link® Communications Card		S
A8NC-CON	CC-Link® Communications Card and Connectors		S
FR-A8ND	DeviceNet™ Communications Card		S
FR-A8NP	PROFIBUS DPV0 Communications Card		S
A8NDPV1	PROFIBUS DPV1 Communications Card		S
FR-A8NF	FL-Net Communications Card		S
A8N-XLT	Multi-protocol RS-485 Communications Card	(BACnet MS/TP), Siemens FLN (P1), Metasys N2	S
A8NEIP-2P	EtherNET™ IP Communications Card		S
A8NPRT-2P	Profinet® Communications Card		S
FR-A8NCE	CC-Link® IE Communications Card		S
A8NECT-2P	EtherCAT® Communications Card		S
A8NETH-2P	Multi-protocol EtherNET Communications Card	EtherNET IP, MODBUS TCP/IP, Profinet, BACnet IP	S
FR-LU08	Liquid Crystal Operation Panel	Mount on VFD or panel	S
FR-LU08-01	LCD Operational Panel (Hand/Auto Key) HVAC		S
FR-PU07, FR-PU07-01	Parameter Unit	Mount on panel only. FR-PU07-1 is for HVAC	S
FR-PU07BB-L	Parameter Unit with Battery Back-up	Hand held. Can program unpowered drives	S
FR-CB20 (_ = 1, 3 or 5)	Parameter Unit Connection Cable	1, 3 or 5 meter lengths	S
FR-ADP	Keypad Adaptor Unit	Connect FR-DU08 or FR-LU08 to FR-CB2	S
FR-A8TAT	Control Terminal Block Adaptor	Use FR-A500 or FR-A700 terminal block with FR-A800	S
FR-A8TR	Screw Terminal Block Option	Screw Terminal Block Option	S
FR-HC2	Zero Harmonic Controller	Available for all sizes	S
FR-HEL, FR-HEL-H, FR-HEL-C	DC Link Chokes	Use in accordance with selection guide	S
FR-CONFIGURATOR2	Software Setup Utility for 800 Series		S

Dimensions of REQUIRED DC Link Chokes (sold separately)

Model Number	Height in (mm)	Width in (mm)	Depth in (mm)	Weight (lbs)
FR-HEL-75K	13.39 (340)	5.91 (150)	7.87 (200)	37.4
FR-HEL-90K	13.39 (340)	5.91 (150)	7.87 (200)	41.8
FR-HEL-110K	15.75 (400)	6.89 (175)	7.87 (200)	44
FR-HEL-H75K	12.60 (320)	5.51 (140)	7.28 (185)	35.2
FR-HEL-H90K	13.39 (340)	5.91 (150)	7.48 (190)	44
FR-HEL-H110K	13.39 (340)	5.91 (150)	7.68 (195)	48.4
FR-HEL-H132K	15.94 (405)	6.89 (175)	7.87 (200)	57.2
FR-HEL-H160K	15.94 (405)	6.89 (175)	8.07 (205)	61.6
FR-HEL-H185K	15.94 (405)	6.89 (175)	9.45 (240)	63.8
FR-HEL-H220K	15.94 (405)	6.89 (175)	9.45 (240)	66
FR-HEL-H250K	17.32 (440)	7.48 (190)	9.84 (250)	77
FR-HEL-H280K	17.32 (440)	7.48 (190)	10.04 (255)	83.6
FR-HEL-H315K	19.49 (495)	8.27 (210)	9.84 (250)	92
FR-HEL-H355K	19.49 (495)	8.27 (210)	9.84 (250)	101
FR-HEL-C75K	12.6 (320)	5.5 (140)	7.3 (185)	35
FR-HEL-C90K	13.3 (340)	5.9 (150)	9.4 (240)	44
FR-HEL-C110K	13.3 (340)	5.9 (150)	9.4 (240)	51
FR-HEL-C132K	15.9 (405)	6.9 (175)	7.7 (195)	53
FR-HEL-C185K	15.9 (405)	6.9 (175)	9.4 (240)	70
FR-HEL-C220K	15.9 (405)	6.9 (175)	9.4 (240)	73
FR-HEL-C280K	17.3 (440)	7.5 (190)	9.8 (250)	88